

技^{日本} March

SCOPE RINGS PRODUCT MANUAL

SAFETY FIRST

- Always Keep The Gun Pointed In A Safe Direction
- Always Keep Your Finger Off The Trigger Until Ready To Shoot
- Always Keep The Gun Unloaded Until Ready To Use

Scope Rings

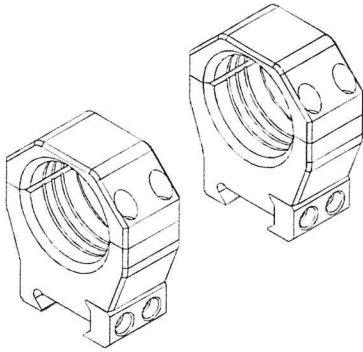

Major Features

- Lightweight and sturdy scope rings
- Precision CNC machined from aircraft grade aluminium billet
- Hardcoat anodizing

Package Content

- Scope rings
- Torx T15 L30mm Screws (4)
- Torx T15 L10mm Screws (8)
- Product manual

Tools Required

- Torx T15 Torque Screwdriver in newton-metre

Installation Instructions

1. Properly place the rings to the Picatinny rail then attach the clamping interfaces by starting L30mm screws into the base.
2. Tighten the clamping interfaces to a final torque value of 3.5Nm max.
3. Place the scope in the rings then attach the caps and start L10mm screws into the base.
4. Check for a comfortable eye relief and level the scope.
5. Tighten the caps to the final torque value suggested by the scope manual. Never exceed 3Nm.
Make sure the gaps on both sides of the rings are equal.

ATTENTION

- Periodically check that the screws are tight
- Never apply threadlocker to the screws